

■ **Product features:**

- ◆ Sony/Sharp CCD
- ◆ 23pcs of IR LED 20m night vision
- ◆ Standard match 3.6mm lens
- ◆ IR auto-open by CDS control in low lux

■ **Picture**



■ **Optional CCD board Model**

Model	Horizontal Resolution	Image Processor	Imaging device
N54	540TVL	SONY	SONY1/3"
N52	520TVL	Netchip	SONY1/3"
N48	480TVL	Netchip	SONY1/3"
N47	470TVL	Netchip	SONY1/3"
N48L	480TVL	SONY	SONY1/3"
N42	420TVL	SONY	SONY1/3"
N42Q	420TVL	SONY	SONY1/4"
P42	420TVL	SHARP	SHARP1/3"
P42Q	420TVL	SHARP	SHARP1/4"

■ **CAD**

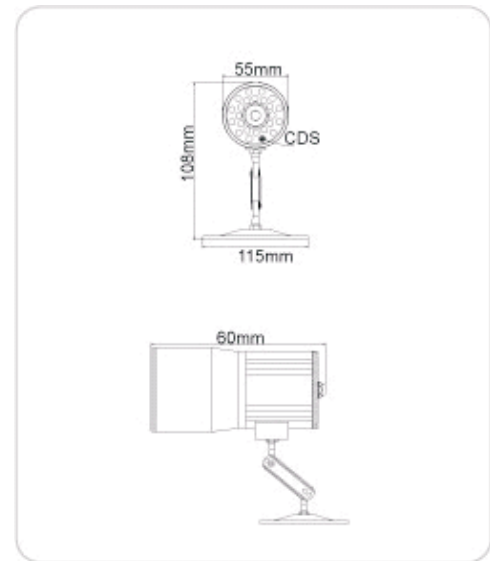

■ **Detailed Specifications Of The Parameters**

Model	N54	N48	N42	P42	P42Q
CCDType	1/3"SONY CCD	1/3"SONY CCD	1/3"SONY CCD	SHARP	1/4"SHARP
Pixels	PAL:795×596	PAL:752×582	PAL:500×582 NTSC:510×492		
	NTSC:811×508	NTSC:768×494			
Horizontal Resolution	540TVL	480TVL	420TVL	420TVL	420TVL
Scanning System	PAL / NTSC				
Level Synchronization frequency	PAL:15.625KHZ / NTSC:15.734KHZ				
Clock frequency	PAL:19.3125 / NISC:19.0699				
Scanning Syste	2:1Deinterlacing				
Minimum Illumination	0.1LUX (Infrared light to open)				
Sync.System	Synchronization				
S/N Ratio	48 dB				
Electronic Shutter	PAL:1/50-1/100,000sec;NTSC:1/60-1/100,000				
Gamma Correction	0.45				
Video Output	1 Vpp,75 Ohms				
AGC	Atuo				
Night vison	non				
Power supply	12VDC (+/-10%)				
Current	350mA				
Carton size	590x360x200mm				
Number of TEUs packaging	30Taiwan				
Dimensions	96x96x63 mm				