

**Product features:**

- ◆Sony/Sharp CCD is optional
- ◆420/480/520/540TVL lines is optional
- ◆BLC and AGC fuction
- ◆AL casing, strong and beautiful
- ◆AES electronic shutter/DC auto-iris fuction

**Picture**



**Optional CCD board Model**

Model	Horizontal Resolution	Image Processor	Imaging device
N54	540TVL	SHARP	SONY1/3"
N52	520TVL	Netchip	SONY1/3"
N48	480TVL	Netchip	SONY1/3"
N47	470TVL	Netchip	SONY1/3"
N48L	480TVL	SONY	SONY1/3"
N42	420TVL	SONY	SONY1/3"
N42Q	420TVL	SONY	SONY1/4"
P42	420TVL	SHARP	SHARP1/3"
P42Q	420TVL	SHARP	SHARP1/4"

**CAD**

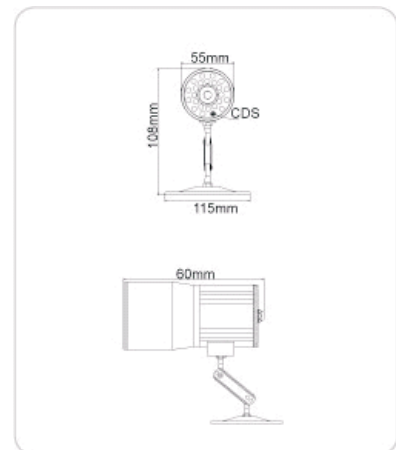

**Detailed Specifications Of The Parameters**

Model	N54	N48	N42	P42	P42Q
CCDType	1/3"SONY CCD	1/3"SONY CCD	1/3"SONY CCD	1/3"SHARP	1/4"SHARP
Pixels	PAL: 795×596	PAL: 752×582	PAL: 500×582 NTSC: 510×492		
	NTSC: 811×508	NTSC: 768×494			
Horizontal Resolution	540TVL	480TVL	420TVL	420TVL	420TVL
Scanning System	PAL / NTSC				
Level Synchronization frequency	PAL: 15.625KHZ / NTSC: 15.734KHZ				
Clock frequency	PAL: 19.3125 / NISC: 19.0699				
Scanning Syste	2:1Deinterlacing				
Minimum Illumination	0.1LUX (Infrared light to open)				
Sync.System	Synchronization				
S/N Ratio	48 dB				
Electronic Shutter	PAL: 1/50-1/100,000sec; NTSC: 1/60-1/100,000				
Gamma Correction	0.45				
Video Output	1 Vpp, 75 Ohms				
AGC	Atuo				
Night vison	non				
Power supply	12VDC(+/-10%)				
Current	120mA				
Carton size	590x360x200mm				
Number of TEUs packaging	30Taiwan				
Dimensions	96x96x63 mm				
Weight	0.11Kg				
Operqting temperature	-10-45°C				
Color	White/black				